

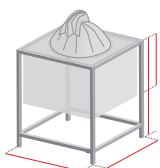

# Pharma Solutions

SUCCESSFUL CUSTOMERS WITH PHARMACEUTICAL LOGISTIC SYSTEM SOLUTIONS BY TISZATEXTIL



**minibag**

**TL**  
**TISZATEXTIL**

European Based Supplier of Quality Bags



**TL**  
**TISZATEXTIL**  
European Based Supplier of Quality Bags

Improving safety, minimizing logistic and process costs, sustaining and improving quality - TiszaTextil Group has the logistic solution to reach these targets.

# successful customers with .

TiszaTextil is a renowned supplier of pharmaceutical logistic solutions which can replace cost-intensive investments in cleaning and transport systems.



Our extensive knowledge of the logistics required for pharmaceutical plants enables us



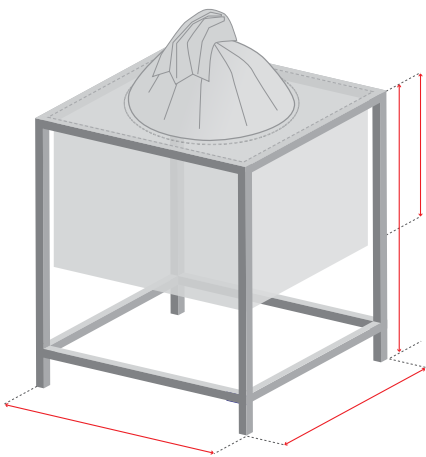

## minibag

The Minibag is designed to offer a safe and economic solution for the transport of solid, finished and semi-finished products. Produced in a state-of-the-art ISO8 cleanroom, the Minibag meets the demands of the European Pharmacopeia and USP for primary packaging.

to provide our customers with innovative and cost-cutting products.





# pharmaceutical logistic syst

As a pollution-free flexible intermediate bulk container it can be used in the whole process of solid drug production.

Starting with the API and excipient handling



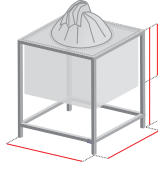

# minibag

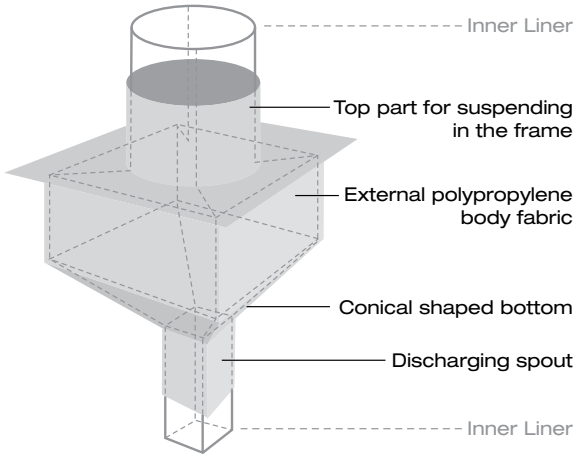

# em solutions



ISO 9000

ISO 14001

ISO 15378

and ending with feeding the final blistering line.





# ... by TiszaTextil

Whether you are designing a new production line or thinking about improving the existing one, we are able to design a logistic solution based on our Minibags and achieve astonishingly high ROI figures.

A customer with a worldwide setup replaced his existing logistic solution with the Minibag. *"Thanks to our expertise and close cooperation we managed to achieve astonishing savings in the whole production process: on average 60% savings on packaging material, logistic costs and quality inspection with the result that the investment was recouped in 2 months."*

Not only for shipping your goods, the Minibag



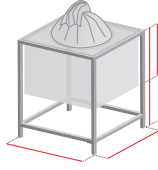

# minibag

Why our worldwide customers choose the Minibag:

- Low investment compared to metal containers
- Easy to fit into existing equipment and processes
- No cross-contamination risk
- Ergonomic handling

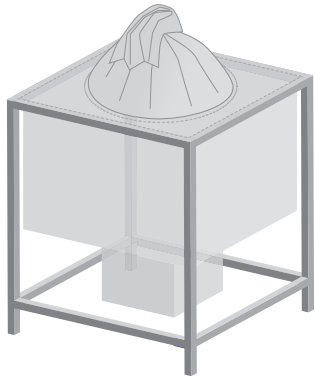

React quickly to increasing market demands. Add as many additional containers to the process as required with low investment and with no extra burden to the washing unit.

**TL**  
**TISZATEXTIL**  
European Based Supplier of Quality Bags

achieves excellent results in all the process steps of solid drug production.



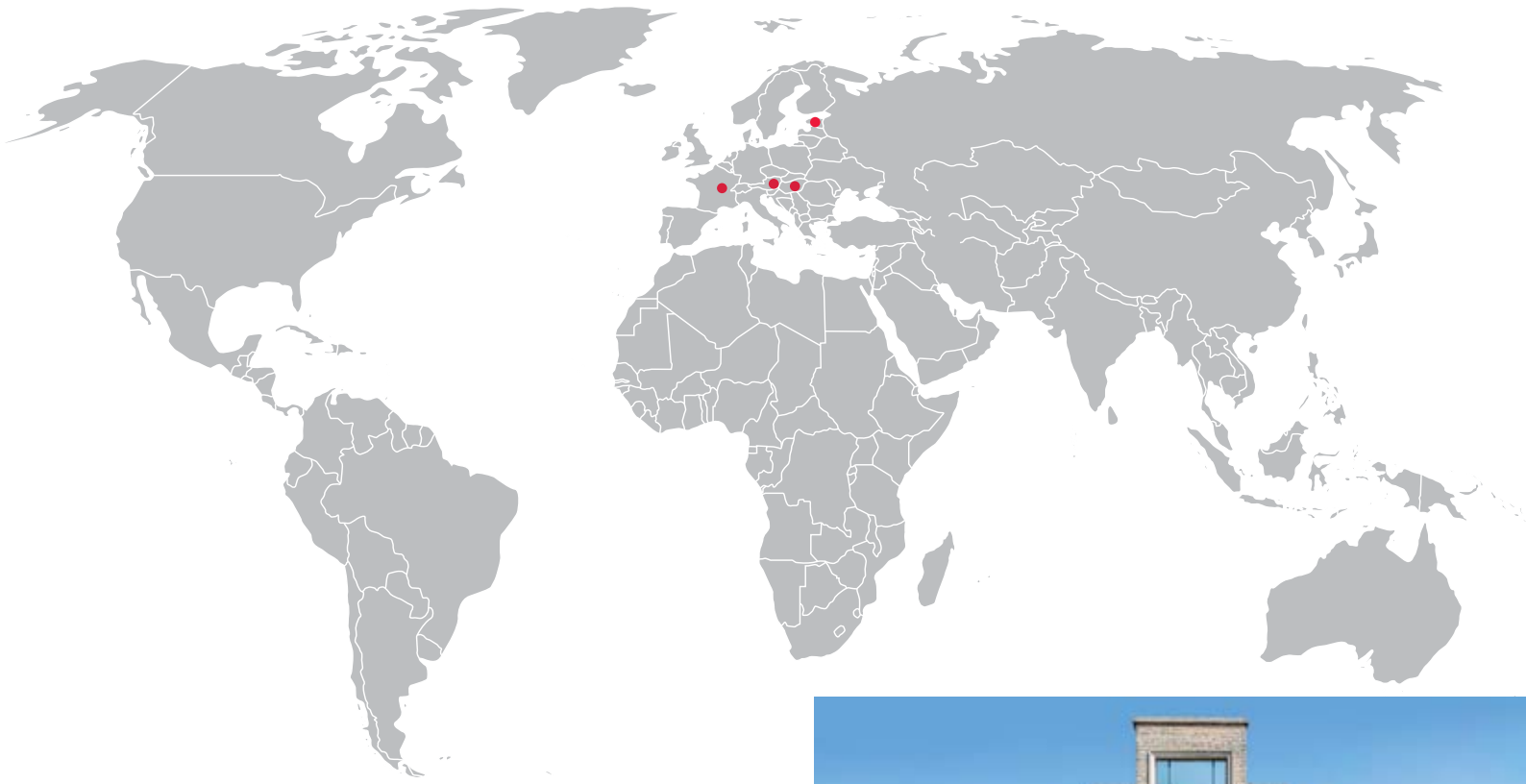

# Pharma Solutions

Pharma approved plant:

TISZATEXTIL Packaging S.A.S, FRANCE PLANT 8 Rue Decomble, 52000 Chaumont



**SUCCESSFUL CUSTOMERS WITH PHARMACEUTICAL LOGISTIC SYSTEM SOLUTIONS BY TISZATEXTIL**

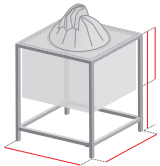

## minibag



Other sites:

TISZATEXTIL Headquarters AUSTRIA,  
Wienerbergstrasse 11/B16, 1100 Vienna

TISZATEXTIL Kft., HUNGARY PLANT  
TVK Ipartelep, hrsz. 2122, 3580 Tiszaújváros

TISZATEXTIL Eesti OÜ Kohtla-Järve, ESTONIA PLANT  
Päikese 1, 30221 Kohtla-Järve

 **Solpharma**  
Technologies

**TL**  
**TISZATEXTIL**  
European Based Supplier of Quality Bags

[www.tiszatextil.com](http://www.tiszatextil.com)